

Two Phase (Two Leg) Installation, U.S
For Filtering All Power From Utility.
 This Configuration Utilizes A Dedicated
 Circuit Breaker, At or Below The
 Current Rating Of The IND Line Inductor.
Do Not Connect IND Line Inductor To Utility
Without A Dedicated Intervening Circuit Breaker.

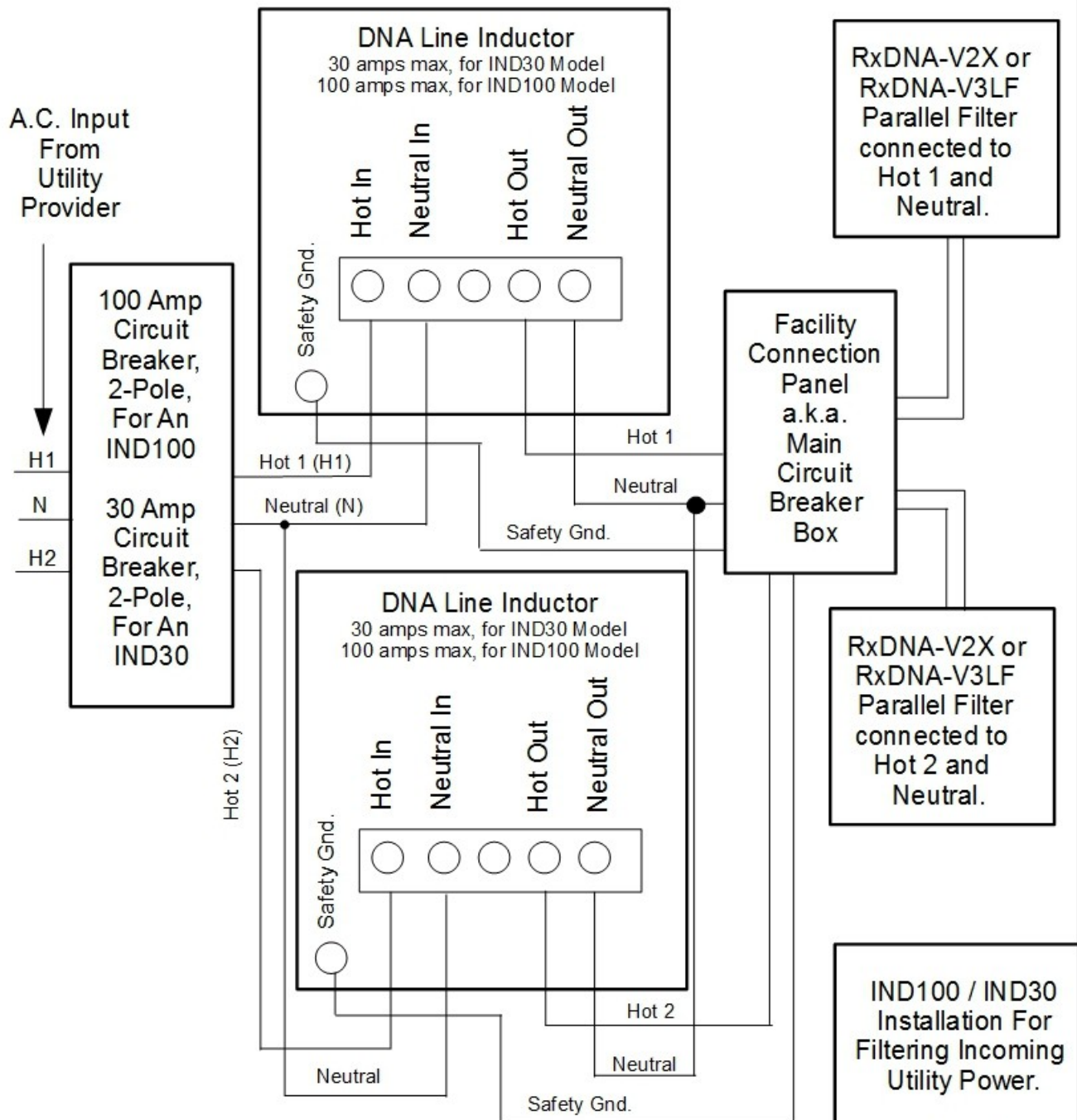

Operational Note For Line Inductors

The DNA Line Inductors are massive inductors. As with all inductors and transformers there is some humming and buzzing associated with this device.

Humming and buzzing from an inductor is caused by stray magnetic fields, emanating from the inductor, causing the enclosure and accessories to vibrate. In addition, Magnetostriction is a second source of vibration (and thereby humming and buzzing), where the iron core of the inductor changes shape minutely when exposed to magnetic fields.

The humming and buzzing will depend upon the load current placed on this device. If the humming/buzzing seems loud, then it is possible that there are loads, within the facility (residential, commercial, industrial) that are drawing current in a pulsed fashion.

An example is a portable electric heater that has a pulse-width-modulation controller to set the amount of heat being produced.

While most heaters have a simple on-off thermostat to regulate the heat, a few heaters have a pulse-width-modulation scheme and will be turning the power off-on-off-on at the power line frequency (50/60 Hz). These pulses of current will often be considerable (10 to 12 amperes) and this will result in loud humming/buzzing in the inductor.

While this humming/buzzing will not affect the filtering performance of the DNA Inductor, the sound may be objectionable.

In the cases where humming or buzzing does occur, and if the user finds humming or buzzing objectionable, the DNA Line Filter can be mounted outdoors, in a weatherproof enclosure, on a pedestal, i.e. not mounted on the building that is occupied. The weatherproof enclosure and pedestal can be provided by the installing electrical contractor.

It is important to note that the idea of installing the DNA Line filter is to reduce DE in the facility. A heater that pulses on-off-on-off at the power line frequency, will be generating DE within the facility and it will be very powerful DE, that likely will extend up to the hundreds of kilohertz in range. Users who want low DE in their facility, would be well advised to not use such potent "DE generators" (the pulsed heater).